

DIVISION: 03 00 00—CONCRETE
Section: 03 16 00—Concrete Anchors

DIVISION: 05 00 00—METALS
Section: 05 05 19—Post-installed Concrete Anchors

REPORT HOLDER:

MITEK® INC.
16023 SWINGLEY RIDGE ROAD
CHESTERFIELD, MISSOURI 63017
(800) 328-5934
www.mitek-us.com
uspcustomerservice@mii.com

EVALUATION SUBJECT:

DUC UNDERCUT ANCHORS

1.0 EVALUATION SCOPE

Compliance with the following codes:

- 2018, 2015, 2012, 2009, and 2006 *International Building Code*® (IBC)
- 2018, 2015, 2012, 2009, and 2006 *International Residential Code*® (IRC)

For evaluation for compliance with codes adopted by the Los Angeles Department of Building and Safety (LADBS), see [ESR-1970 LABC and LARC Supplement](#).

Property evaluated:

Structural

2.0 USES

The DUC Undercut Anchor is used to resist static, wind, and seismic tension and shear loads in cracked and uncracked normal-weight and lightweight concrete having a specified compressive strength, f_c , of 2,500 psi to 8,500 psi (17.2 MPa to 58.6 MPa). The DUC anchors comply as anchors installed in hardened concrete as described in Section 1901.3 of the 2018 and 2015 IBC, Section 1909 of the 2012 IBC, and Section 1912 of the 2009 and 2006 IBC. The anchors are an alternative to cast-in-place anchors described in Section 1908 of the 2012 IBC, and Section 1911 of the 2009 and 2006 IBC. The anchors may also be used where an engineered design is submitted in accordance with Section R301.1.3 of the IRC.

3.0 DESCRIPTION

3.1 General:

The DUC Undercut Anchors are displacement controlled undercut anchors. The DUC Undercut Anchors are

comprised of five components as shown in Figure 1. The expanded anchor sleeve creates a mechanical interlock with the surrounding concrete. The DUC Undercut Anchors are available in standard (L and H designations) and through-bolted (LT and HT designations) versions with component dimensions as listed in Table 1. Sizes available include $\frac{3}{8}$ -inch (9.5 mm), $\frac{1}{2}$ -inch (12.7 mm), $\frac{5}{8}$ -inch (15.9 mm), and $\frac{3}{4}$ -inch (19.1 mm) diameters and various lengths. Table 1 shows anchor dimensions.

3.2 Anchor Materials:

3.2.1 Threaded Rods: The steel threaded rods used with the low-strength (L designation) anchors are ASTM A36 (F1554 Grade 36) low carbon steel and have a minimum 0.0002-inch (5 μ m) zinc plating in accordance with ASTM B633, Type I. The steel threaded rods used with the high-strength (H designation) anchors comply with ASTM A193 Grade B7 and have a minimum 0.0002-inch (5 μ m) yellow zinc plating in accordance with ASTM B633, Type II. A painted red setting mark (used for visual setting control) is provided on the threaded rod of both the low- and high-strength anchors.

3.2.2 Sleeves: The steel expansion sleeves comply with ASTM A513 Type 5 ERW DOM, with a minimum yield strength of 70,000 psi (483 MPa) and a minimum tensile strength of 80,000 psi (552 MPa). The sleeves have a minimum 0.0002-inch-thick (5 μ m) yellow zinc plating in accordance with ASTM B633, Type II.

3.2.3 Coupling: The steel expansion couplings comply with ASTM A108 Type 12L14.

3.2.4 Nut and Washer: The hex nuts comply with ASTM A563, Grade A. The washers comply with ASTM F844.

3.3 Concrete:

Normal-weight and lightweight concrete must conform to Sections 1903 and 1905 of the IBC, as applicable.

4.0 DESIGN AND INSTALLATION

4.1 Strength Design:

4.1.1 Design Strength of anchors complying with the 2018 and 2015 IBC and Section R301.1.3 of the 2018 and 2015 IRC must be determined in accordance with ACI 318-14 Chapter 17 and this report.

Design strength of anchors complying with the 2012 IBC and Section R301.1.3 of the 2012 IRC, must be determined in accordance with ACI 318-11 Appendix D and this report.

Design strength of anchors complying with the 2009 IBC and Section R301.1.3 of 2009 IRC must be in accordance with ACI 318-08 Appendix D and this report.

Design strength of anchors complying with the 2006 IBC and Section R301.1.3 of 2006 IRC must be in accordance with ACI 318-05 Appendix D and this report.

Design examples according to the 2018, 2015 and 2012 IBC are given in Figures 5, 6, and 7 of this report. Design parameters are described in Tables 4 and 5 of this report and are based on the 2018 and 2015 IBC (ACI 318-14) and 2012 IBC (ACI 318-11) unless noted otherwise in Sections 4.1.1 through 4.1.12. The strength design of anchors must comply with ACI 318-14 17.3.1 or ACI 318-11 D.4.1, except as required in ACI 318-14 17.2.3 or ACI 318-11 D.3.3, as applicable.

Strength reduction factors, ϕ , as given in ACI 318-14 17.3.3 or ACI 318-11 D.4.3, as applicable, and Table 4 must be used for load combinations calculated in accordance with Section 1605.2 of the IBC and Section 5.3 of ACI 318-14 or Section 9.2 of ACI 318-11, as applicable. Strength reduction factors, ϕ , as given in ACI 318-11 D.4.4 must be used for load combinations calculated in accordance with ACI 318-11 Appendix C.

The value of f'_c used in the calculations must be limited to a maximum of 8,000 psi (55.2 MPa), in accordance with ACI 318-14 17.2.7 or ACI 318-11 D.3.7.

4.1.2 Requirements for Static Steel Strength in Tension, N_{sa} : The nominal steel strength of a single anchor in tension, N_{sa} , must be calculated in accordance with ACI 318-14 17.4.1.2 or ACI 318-11 D.5.1.2, as applicable. The resulting values of N_{sa} are described in Table 4 of this report. Strength reduction factors, ϕ , corresponding to ductile steel elements may be used.

4.1.3 Requirements for Static Concrete Breakout Strength in Tension, N_{cb} or N_{cbg} : The nominal concrete breakout strength of a single anchor or group of anchors in tension, N_{cb} and N_{cbg} , respectively, must be calculated in accordance with ACI 318-14 17.4.2 or ACI 318-11 D.5.2, as applicable, and modifications as described in this section. The basic concrete breakout strength of a single anchor in tension in regions where analysis indicates cracking, N_b , must be calculated according to ACI 318-14 17.4.2.2 or ACI 318-11 D.5.2.2, as applicable, using the values of h_{ef} and K_{cr} as described in Table 4 of this report. Concrete breakout strength in tension in regions where analysis indicates no cracking in accordance with ACI 318-14 17.4.2.6 or ACI 318-11 D.5.2.6, as applicable, must be calculated with $\psi_{c,N} = 1.0$ and using the value of k_{unecr} as given in Table 4 of this report.

4.1.4 Requirements for Static Pullout Strength in Tension, N_{pn} : The nominal pullout strength of a single anchor or a group of anchors in tension, in accordance with ACI 318-14 17.4.3 or ACI 318-11 D.5.3, as applicable, in cracked concrete, $N_{p,cr}$, is given in Table 4 of this report. For all design cases, $\psi_{c,P} = 1.0$. In accordance with ACI 318-14 17.4.3.2 or ACI 318-11 D.5.3.2, as applicable, the nominal pullout strength in cracked concrete must be adjusted by calculation according to Eq-1:

$$N_{pn,f'c} = N_{p,cr} \sqrt{\frac{f'_c}{2,500}} \quad (\text{lb, psi}) \quad (\text{Eq-1})$$

$$N_{pn,f'c} = N_{p,cr} \sqrt{\frac{f'_c}{17.2}} \quad (\text{N, MPa})$$

In uncracked concrete, pullout strength does not control and therefore need not be evaluated.

4.1.5 Requirements for Static Steel Strength in Shear, V_{sa} : The nominal steel strength in shear, V_{sa} , of a single anchor in accordance with ACI 318-14 17.5.1.2 or ACI 318-11 D.6.1.2, as applicable, is given in

Table 4 for the standard type and through-bolt type anchors and must be used in lieu of the values derived by calculation from ACI 318-14 Eq. 17.5.1.2b or ACI 318-11 Eq. D-29, as applicable. Strength reduction factors, ϕ , corresponding to ductile steel elements must be used.

4.1.6 Requirements for Static Concrete Breakout Strength in Shear, V_{cb} or V_{cbg} : The nominal static concrete breakout strength of a single anchor or a group of anchors in shear, V_{cb} or V_{cbg} , respectively, must be calculated in accordance with ACI 318-14 17.5.2 or ACI 318-11 D.6.2, as applicable, with modifications as described in this section. The basic concrete breakout strength of a single anchor in shear must be calculated in accordance with ACI 318-14 17.5.2.2 or ACI 318-11 D.6.2.2, as applicable, where the value of l_e used in ACI 318-14 Eq. 17.5.2.2a or ACI 318-11 Eq. D-33 must be taken as h_{ef} , but no greater than $8d_a$, for the anchors with one tubular shell over full length of the embedment depth; or the value of l_e used in ACI 318-14 Eq. 17.5.2.2a or ACI 318-11 Eq. D-33 must be taken as $2d_a$ for the anchors with a distance sleeve separated from the expansion sleeve.

4.1.7 Requirements for Static Concrete Pryout Strength in Shear, V_{cp} or V_{cpg} : The nominal static concrete pryout strength of a single anchor or a group of anchors in shear, V_{cp} or V_{cpg} , respectively, must be calculated in accordance with ACI 318-14 17.5.3 or ACI 318-11 D.6.3, as applicable, modified by using the value k_{cp} provided in Table 4 and the value N_{cb} and N_{cbg} as calculated in Section 4.1.3 of this report.

4.1.8 Requirements for Seismic Design: General: For load combinations including seismic, the design must be performed in accordance with ACI 318-14 17.2.3 or ACI 318-11 D.3.3, as applicable. Modifications to ACI 318-14 17.2.3 shall be applied under Section 1905.1.8 of the 2018 and 2015 IBC. For the 2012 IBC, Section 1905.1.9 shall be omitted. Modifications to ACI 318 (-08, -05) D.3.3 must be applied under Section 1908.1.9 of the 2009 IBC or Section 1908.1.16 of the 2006 IBC, as applicable.

The L, LT, H, and HT designated anchors comply with ACI 318-14 2.3 or ACI 318-11 D.1, as applicable, as ductile steel elements and must be designed in accordance with ACI 318-14, 17.2.3.4, 17.2.3.5, 17.2.3.6 or 17.2.3.7; ACI 318-11 D.3.3.4, D.3.3.5, D.3.3.6, and D.3.3.7; ACI 318-08 D.3.3.4, D.3.3.5, or D.3.3.6; or ACI 318-05 D.3.3.4 or D.3.3.5, as applicable.

4.1.8.1 Seismic Tension: The nominal steel strength and nominal concrete breakout strength for anchors in tension must be calculated in accordance with ACI 318-14 17.4.1 and 17.4.2 or ACI 318-11 D.5.1 and D.5.2, respectively, as applicable, as described in Sections 4.1.2 and 4.1.3 of this report. In accordance with ACI 318-14 17.4.3.2 or ACI 318-11 D.5.3.2, as applicable, the appropriate value for pullout strength in tension for seismic loads, $N_{p,eq}$, described in Table 4 of this report must be used in lieu of N_p . $N_{p,eq}$ may be adjusted by calculations for concrete compressive strength in accordance with Eq-1 of this report.

4.1.8.2 Seismic Shear: The nominal concrete breakout strength and pryout strength for anchors in shear must be calculated according to ACI 318-14 17.5.2 and 17.5.3 or ACI 318-11 D.6.2 and D.6.3, respectively, as applicable, as described in Sections 4.1.6 and 4.1.7 of this report. In accordance with ACI 318-14 17.5.1.2 or ACI 318-11 D.6.1.2, as applicable, the appropriate value for nominal steel strength in shear for seismic loads $V_{sa,eq}$, described in Table 4 must be used in lieu of V_{sa} .

4.1.9 Requirements for Interaction of Tensile and Shear Forces: The effects of combined tensile and

shear forces must be determined in accordance with ACI 318-14 17.6 or ACI 318-11 D.7, as applicable.

4.1.10 Requirements for Critical Edge Distance: In applications where $c < c_{ac}$ and supplemental reinforcement to control splitting of the concrete is not present, the concrete breakout strength in tension for uncracked concrete, calculated according to ACI 318-14 17.4.2 or ACI 318-11 D.5.2, as applicable, must be further multiplied by the factor $\psi_{cp,N}$ given in the following equation:

$$\psi_{cp,N} = \frac{c}{c_{ac}} \quad (\text{Eq-2})$$

whereby the factor $\psi_{cp,N}$ need not be taken as less than $\frac{1.5h_{ef}}{c_{ac}}$. For all other cases $\psi_{cp,N} = 1.0$. In lieu of ACI 318-14 17.7.6 or ACI 318-11 D.8.6, as applicable, values of c_{ac} critical edge distance must be in accordance with Table 4 of this report.

4.1.11 Requirements for Minimum Member Thickness, Minimum Anchor Spacing and Minimum Edge Distance: In lieu of ACI 318-14 17.7.1 and 17.7.3 or ACI 318-11 D.8.1 and D.8.3, respectively, as applicable, values of s_{min} and c_{min} provided in Table 4 of this report must be used. In lieu of ACI 318-14 17.7.5 or ACI 318-11 D.8.5, as applicable, minimum member thickness, h_{min} , must be in accordance with Table 4 of this report.

4.1.12 Requirements for Lightweight Concrete: For the use of anchors in lightweight concrete, the modification factor λ_a equal to 1.0λ is applied to all values of $\sqrt{f'_c}$ affecting N_n and V_n .

For ACI 318-14 (2018 and 2015 IBC), ACI 318-11 (2012 IBC) and ACI 318-08 (2009 IBC), λ shall be determined in accordance with the corresponding version of ACI 318.

For ACI 318-05 (2006 IBC), λ shall be taken as 0.75 for all lightweight concrete and 0.85 for sand-lightweight concrete. Linear interpolation shall be permitted if partial sand replacement is used. In addition, the pullout strengths $N_{p,cr}$ and $N_{p,eq}$ shall be multiplied by the modification factor, λ_a , as applicable.

4.2 Allowable Stress Design:

4.2.1 General: For anchors designed using load combinations in accordance with IBC Section 1605.3 (Allowable Stress Design), allowable loads must be established using the equations below:

$$T_{allowable,ASD} = \frac{\phi N_n}{\alpha} \quad (\text{Eq-3})$$

$$V_{allowable,ASD} = \frac{\phi V_n}{\alpha} \quad (\text{Eq-4})$$

where:

$T_{allowable,ASD}$ = Allowable tension load (lb or N).

$V_{allowable,ASD}$ = Allowable shear load (lb or N).

ϕN_n = Lowest design strength of an anchor or anchor group in tension as determined in accordance with ACI 318-14 Chapter 17, 2018 and 2015 IBC Section 1905.1.8, ACI 318-11 Appendix D, ACI 318-08 Appendix D and 2009 IBC Section 1908.1.9, ACI 318-05 Appendix D and 2006 IBC Section 1908.1.16, and Section 4.1 of this report, as applicable (lb or N). For the 2012 IBC, Section 1905.1.9 shall be omitted.

ϕV_n = Lowest design strength of an anchor or anchor group in shear as determined

in accordance with ACI 318-14 Chapter 17, 2018 and 2015 IBC Section 1905.1.8, ACI 318-11 Appendix D, ACI 318-08 Appendix D and 2009 IBC Section 1908.1.9, ACI 318-05 Appendix D and 2006 IBC Section 1908.1.16, and Section 4.1 of this report, as applicable (lb or N). For the 2012 IBC, Section 1905.1.9 shall be omitted.

α = Conversion factor calculated as a weighted average of the load factors for the controlling load combination. In addition, α must include all applicable factors to account for non-ductile failure modes and required over-strength.

Limits on edge distance, anchor spacing, and member thickness as given in Table 4 must apply. An example of Allowable Stress Design tension values is given in Table 5.

4.2.2 Interaction of Tensile and Shear Forces: The interaction must be calculated and consistent with ACI 318-14 17.6 or ACI 318 (-11, -08, -05) D.7 as follows:

For shear loads $V \leq 0.2 V_{allowable,ASD}$, the full allowable load in tension must be permitted.

For tension loads $T \leq 0.2 T_{allowable,ASD}$, the full allowable load in shear must be permitted.

For all other cases:

$$\frac{T}{T_{allowable}} + \frac{V}{V_{allowable}} \leq 1.2 \quad (\text{Eq-5})$$

4.3 Installation:

Installation parameters are described in Tables 1 through 4 and Figures 2 through 5 of this report. Anchor locations must comply with the plans and specifications approved by the code official and this report. Anchors must be installed in accordance with MiTek instructions and this report. Holes must be drilled normal to the concrete surface using carbide-tipped masonry stop drill bits complying with ANSI B212.15-1994 supplied by MiTek. The holes must be cleaned using a hand pump or compressed air. The undercut drill bit must then be inserted into the hole and drilled until the stopper sleeve is fully compressed and the gap is closed. The holes must be cleaned again using a hand pump or compressed air. The DUC anchors must be inserted into the holes without nut and washer and the setting sleeve must be placed on the anchor and hammered to drive the expansion sleeve over the expansion coupling. Proper setting requires the red setting mark on the threaded rod to be visible above the expansion sleeve. The setting sleeve must be removed and the attachment must then be placed over the threaded rod and secured by the nut and washer. The maximum applied torque, T_{max} , must not exceed the values given in Table 3. Undercut drill bits and setting tools used are provided by MiTek.

4.4 Special Inspection:

Periodic special inspection is required, in accordance with Section 1705.1.1 and Table 1705.3 of the 2018, 2015 and 2012 IBC; Section 1704.15 and Table 1704.4 of the 2009 IBC; or Section 1704.13 of the 2006 IBC, as applicable. The special inspector must make periodic inspections during anchor installation to verify anchor type, anchor dimensions, concrete type, concrete compressive strength, hole dimensions, hole cleaning procedure, anchor spacing, edge distances, concrete thickness, anchor embedment, tightening torque and adherence to the manufacturer's printed installation instructions. The special inspector must be present as often as required in accordance with the "statement of special inspection." Under the IBC, additional

requirements as set forth in Chapter 17 must be observed, where applicable.

5.0 CONDITIONS OF USE

The DUC Undercut Anchors described in this report comply with, or are suitable alternatives to what is specified in, those codes listed in Section 1.0 of this report, subject to the following conditions:

- 5.1 Anchor sizes, dimensions, and minimum embedment depths are as set forth in the tables of this report.
- 5.2 The anchors must be installed in accordance with the manufacturer’s published installation instructions and this report. In cases of a conflict, this report governs.
- 5.3 Anchors must be limited to use in concrete with a specified strength, f'_c , from 2,500 to 8,500 psi (17.2 to 58.6 MPa).
- 5.4 The values of f'_c used for calculation purposes must not exceed 8,000 psi (55.1 MPa).
- 5.5 Strength design values must be established in accordance with Section 4.1 of this report.
- 5.6 Allowable stress design values must be established in accordance with Section 4.2 of this report.
- 5.7 Anchor spacing and edge distance, as well as minimum member thickness, must comply with Table 4 of this report.
- 5.8 Prior to installation, calculations and details demonstrating compliance with this report must be submitted to the code official for approval. The calculations and details must be prepared by a registered design professional where required by the statutes of the jurisdiction in which the project is to be constructed.
- 5.9 Since an ICC-ES acceptance criteria for evaluating data to determine the performance of undercut anchors subjected to fatigue or shock loading is unavailable at this time, the use of these anchors under these conditions is beyond the scope of the report.
- 5.10 Anchors may be installed in regions of concrete where cracking has occurred or where analysis indicates cracking may occur ($f_i > f_r$), subject to the conditions of this report.

- 5.11 Anchors may be used to resist short-term loading due to wind or seismic forces, subject to the conditions of this report.
- 5.12 Where not otherwise prohibited in the code, anchors are permitted for installation in fire-resistance rated construction provided that at least one of the following conditions is fulfilled:
 - Anchors are used to resist wind or seismic forces only.
 - Anchors that support a fire-resistance-rated envelope or a fire-resistance-rated membrane are protected by approved fire-resistance-rated materials, or have been evaluated for resistance to fire exposure in accordance with recognized standards.
 - Anchors are used to support nonstructural elements.
- 5.13 Use of zinc-coated carbon steel anchors must be limited to dry, interior locations.
- 5.14 Special inspection must be provided in accordance with Section 4.4.
- 5.15 Anchors are manufactured under an approved quality control program with inspections by ICC-ES.
- 5.16 Axial Stiffness values are shown in Table A.

6.0 EVIDENCE SUBMITTED

Data in accordance with the ICC-ES Acceptance Criteria for Mechanical Anchors in Concrete Elements (AC193), dated October 2017 (editorially revised April 2018), which incorporates requirements in ACI 355.2-07 / 355.2-04, for use in cracked and uncracked concrete; including optional suitability tests for seismic tension and shear; and quality control documentation.

7.0 IDENTIFICATION

The anchors are identified by a length letter code head marking stamped on the exposed end of the rod, and packaging labeled with the company name (MiTek) and address, anchor name, anchor size, evaluation report number (ESR-1970).

TABLE A—AXIAL STIFFNESS VALUES, β , FOR DUC UNDERCUT ANCHORS IN NORMAL-WEIGHT CONCRETE¹

Concrete State	Notation	Units	Nominal Anchor Size / Rod Diameter (inch)			
			³ / ₈	¹ / ₂	⁵ / ₈	³ / ₄
Uncracked concrete	β_{min}	10 ³ lbf/in. (kN/mm)	131 (23)			
	β_m	10 ³ lbf/in. (kN/mm)	930 (163)			
	β_{max}	10 ³ lbf/in. (kN/mm)	1,444 (253)			
Cracked concrete	β_{min}	10 ³ lbf/in. (kN/mm)	91 (16)			
	β_m	10 ³ lbf/in. (kN/mm)	394 (69)			
	β_{max}	10 ³ lbf/in. (kN/mm)	1,724 (302)			

¹Valid for anchors with high strength threaded rod (A193 Grade B7). For anchors with low strength threaded rod (A36) values must be multiplied by 0.7.

TABLE 1—DUC UNDERCUT ANCHOR DIMENSIONAL CHARACTERISTICS¹

Anchor Designation	Anchor Type	Anchor Rod ASTM Designation	Rod Diameter, d_b (inch)	Anchor Length, l_b (inches)	Sleeve Length, l_s (inches)	Sleeve Diameter, d_s (inch)	Expansion Coupling Dia., d_c (inch)	Max. Fixture Thickness, t (inches)
DUC38-275L	Standard	A36	$\frac{3}{8}$	$5\frac{1}{2}$	$2\frac{3}{4}$	$\frac{5}{8}$	$\frac{5}{8}$	$1\frac{3}{4}$
DUC38-275LT	Through bolt (TB)	A36	$\frac{3}{8}$	$5\frac{1}{2}$	$4\frac{1}{2}$	$\frac{5}{8}$	$\frac{5}{8}$	$1\frac{3}{4}$
DUC38-400H	Standard	A193, Grade B7	$\frac{3}{8}$	$6\frac{3}{4}$	4	$\frac{5}{8}$	$\frac{5}{8}$	$1\frac{3}{4}$
DUC38-400HT	Through bolt (TB)	A193, Grade B7	$\frac{3}{8}$	$6\frac{3}{4}$	$5\frac{3}{4}$	$\frac{5}{8}$	$\frac{5}{8}$	$1\frac{3}{4}$
DUC12-400L	Standard	A36	$\frac{1}{2}$	7	4	$\frac{3}{4}$	$\frac{3}{4}$	$1\frac{3}{4}$
DUC12-400LT	Through bolt (TB)	A36	$\frac{1}{2}$	7	$5\frac{3}{4}$	$\frac{3}{4}$	$\frac{3}{4}$	$1\frac{3}{4}$
DUC12-500H	Standard	A193, Grade B7	$\frac{1}{2}$	8	5	$\frac{3}{4}$	$\frac{3}{4}$	$1\frac{3}{4}$
DUC12-500HT	Through bolt (TB)	A193, Grade B7	$\frac{1}{2}$	8	$6\frac{3}{4}$	$\frac{3}{4}$	$\frac{3}{4}$	$1\frac{3}{4}$
DUC12-675H	Standard	A193, Grade B7	$\frac{1}{2}$	$9\frac{3}{4}$	$6\frac{3}{4}$	$\frac{3}{4}$	$\frac{3}{4}$	$1\frac{3}{4}$
DUC12-675HT	Through bolt (TB)	A193, Grade B7	$\frac{1}{2}$	$9\frac{3}{4}$	$8\frac{1}{2}$	$\frac{3}{4}$	$\frac{3}{4}$	$1\frac{3}{4}$
DUC58-450L	Standard	A36	$\frac{5}{8}$	$7\frac{3}{4}$	$4\frac{1}{2}$	1	1	$1\frac{3}{4}$
DUC58-450LT	Through bolt (TB)	A36	$\frac{5}{8}$	$7\frac{3}{4}$	$6\frac{1}{4}$	1	1	$1\frac{3}{4}$
DUC58-750H	Standard	A193, Grade B7	$\frac{5}{8}$	$10\frac{3}{4}$	$7\frac{1}{2}$	1	1	$1\frac{3}{4}$
DUC58-750HT	Through bolt (TB)	A193, Grade B7	$\frac{5}{8}$	$10\frac{3}{4}$	$9\frac{1}{4}$	1	1	$1\frac{3}{4}$
DUC58-900H	Standard	A193, Grade B7	$\frac{5}{8}$	$12\frac{1}{4}$	9	1	1	$1\frac{3}{4}$
DUC58-900HT	Through bolt (TB)	A193, Grade B7	$\frac{5}{8}$	$12\frac{1}{4}$	$10\frac{3}{4}$	1	1	$1\frac{3}{4}$
DUC34-500L	Standard	A36	$\frac{3}{4}$	$8\frac{5}{8}$	5	$1\frac{1}{8}$	$1\frac{1}{8}$	$1\frac{3}{4}$
DUC34-500LT	Through bolt (TB)	A36	$\frac{3}{4}$	$8\frac{5}{8}$	$6\frac{3}{4}$	$1\frac{1}{8}$	$1\frac{1}{8}$	$1\frac{3}{4}$
DUC34-1000H	Standard	A193, Grade B7	$\frac{3}{4}$	$13\frac{5}{8}$	10	$1\frac{1}{8}$	$1\frac{1}{8}$	$1\frac{3}{4}$
DUC34-1000HT	Through bolt (TB)	A193, Grade B7	$\frac{3}{4}$	$13\frac{5}{8}$	$11\frac{3}{4}$	$1\frac{1}{8}$	$1\frac{1}{8}$	$1\frac{3}{4}$

For SI: 1 inch = 25.4 mm.

¹Threaded anchor rod conforming to ASTM F1554, Grade 36 is equivalent to threaded anchor rod with ASTM A36 designation.

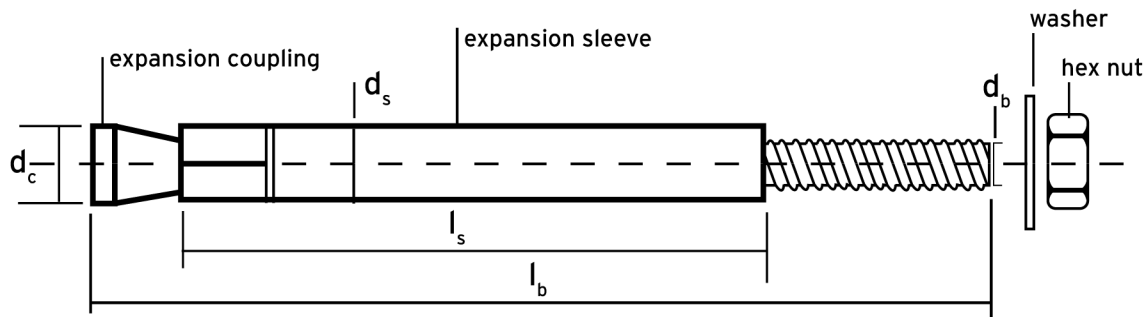
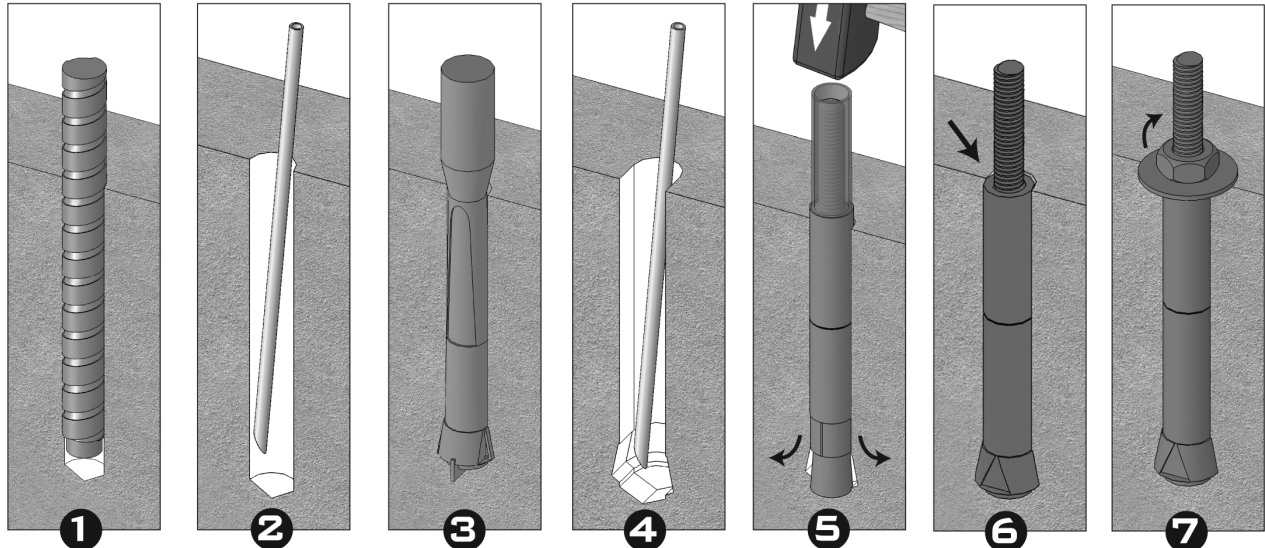

FIGURE 1—DUC UNDERCUT ANCHOR ASSEMBLY

TABLE 2—ANCHOR LENGTH CODE IDENTIFICATION SYSTEM

Length ID marking on anchor rod head		A	B	C	D	E	F	G	H	I	J	K	L	M	N	O	P	Q	R	S	T	U
Anchor length, l_b , (inches)	From	$1\frac{1}{2}$	2	$2\frac{1}{2}$	3	$3\frac{1}{2}$	4	$4\frac{1}{2}$	5	$5\frac{1}{2}$	6	$6\frac{1}{2}$	7	$7\frac{1}{2}$	8	$8\frac{1}{2}$	9	$9\frac{1}{2}$	10	11	12	13
	Up to but not including	2	$2\frac{1}{2}$	3	$3\frac{1}{2}$	4	$4\frac{1}{2}$	5	$5\frac{1}{2}$	6	$6\frac{1}{2}$	7	$7\frac{1}{2}$	8	$8\frac{1}{2}$	9	$9\frac{1}{2}$	10	11	12	13	14

For SI: 1 inch = 25.4 mm.



1
Drill the hole to proper depth and diameter per specifications using rotohammer and stop drill.

2
Clean the hole using a blow-out bulb or compressed air.

3
Insert the undercut bit and start the rotohammer. Undercutting is complete when the stopper sleeve is fully compressed (gap closed).

4
Clean the hole again using a blow-out bulb or compressed air.

5
Insert anchor into hole. Place setting sleeve over anchor and drive the expansion sleeve over the expansion coupling.

6
Verify that the setting mark is visible on the threaded rod above the sleeve.

7
Apply proper torque.

FIGURE 2—INSTALLATION OF DUC UNDERCUT ANCHOR

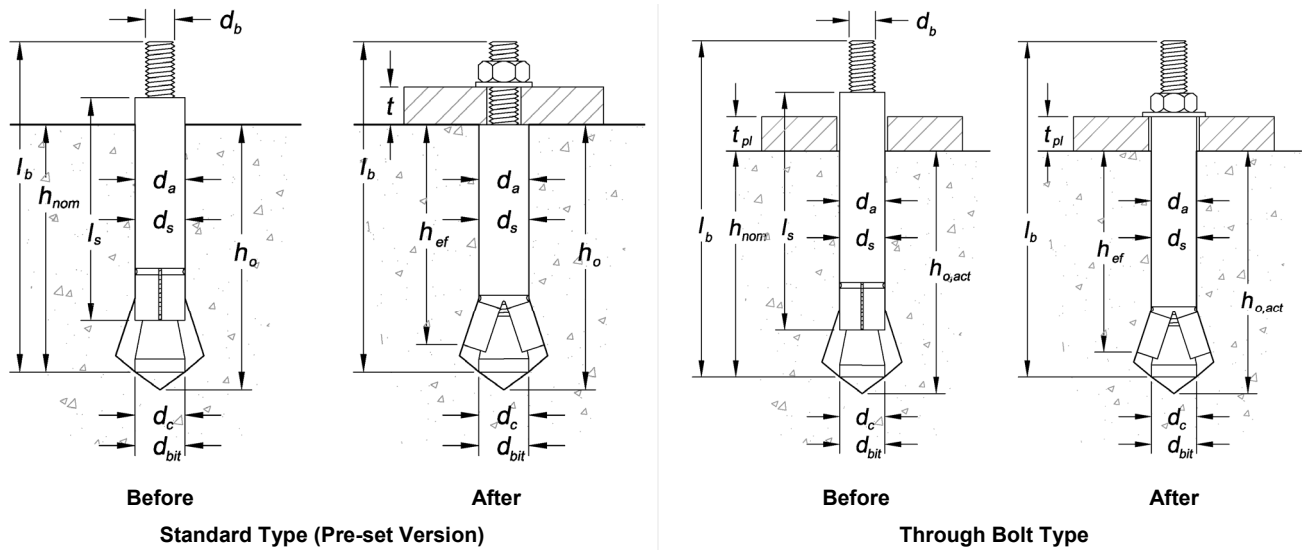

FIGURE 3—DUC UNDERCUT ANCHOR DETAIL
Before and After Application of Setting Sleeve and Attachment

TABLE 3—DUC UNDERCUT ANCHOR INSTALLATION SPECIFICATIONS

Anchor Property / Setting Information	Notation	Units	Nominal Anchor Size / Rod Diameter (inch)									
			3/8		1/2			5/8			3/4	
Outside anchor diameter	d_a [d_o] ³	in. (mm)	0.625 (15.9)		0.750 (19.1)			1.000 (25.4)			1.125 (28.6)	
Nominal embedment depth	h_{nom}	in. (mm)	3 1/8 (79)	4 3/8 (111)	4 1/4 (108)	5 1/4 (133)	7 (178)	5 (127)	8 (203)	9 1/2 (241)	5 7/8 (149)	10 7/8 (276)
Effective embedment depth	h_{ef}	in. (mm)	2 3/4 (70)	4 (102)	4 (102)	5 (127)	6 3/4 (171)	4 1/2 (114)	7 1/2 (190)	9 (229)	5 (127)	10 (254)
Minimum hole depth ¹	h_o	in. (mm)	3 1/8 (79)	4 3/8 (111)	4 1/4 (108)	5 1/4 (133)	7 (178)	5 (127)	8 (203)	9 1/2 (241)	5 7/8 (149)	10 7/8 (276)
Minimum diameter of hole clearance in fixture ²	d_h	in. (mm)	7/16 (11.1)		9/16 (14.3)			1 1/16 (17.5)			1 3/16 (20.6)	
Maximum thickness of fixture	t	in. (mm)	1 3/4 (44)		1 3/4 (44)			1 3/4 (44)			1 3/4 (44)	
Maximum torque	T_{max}	ft.-lbf.	26		44			60			133	
Torque wrench / socket size	-	in.	9/16		3/4			15/16			1 1/8	
Nut height	-	in.	2 1/64		7/16			35/64			4 1/64	
Stop Drill Bit												
Nominal stop drill bit diameter	d_{bit}	in.	5/8 ANSI		3/4 ANSI			1 ANSI			1 1/8 ANSI	
Stop drill bit for anchor installation	-	-	DUCSB 38-275	DUCSB 38-400	DUCSB 12-400	DUCSB 12-500	DUCSB 12-675	DUCSB 58-450	DUCSB 58-750	DUCSB 58-900	DUCSB 34-500	DUCSB 34-1000
Drilled hole depth of stop bit ¹	-	in. (mm)	3 1/8 (79)	4 3/8 (111)	4 1/4 (108)	5 1/4 (133)	7 (178)	5 (127)	8 (203)	9 1/2 (241)	5 7/8 (149)	10 7/8 (276)
Stop drill bit shank type	-	-	SDS		SDS			SDS-Max			SDS-Max	
Undercut Drill Bit												
Nominal undercut drill bit diameter	d_{uc}	in.	5/8		3/4			1			1 1/8	
Undercut drill bit designation	-	-	UCB58		UCB34			UCB100			UCB118	
Maximum depth of hole for undercut drill bit	-	in. (mm)	9 (229)		10 1/4 (260)			12 1/4 (311)			13 1/2 (343)	
Undercut drill bit shank type	-	-	SDS		SDS			SDS-Max			SDS-Max	
Required impact drill energy	-	ft.-lbf.	1.6		2.5			3.2			4	
Setting Sleeve												
Recommended setting sleeve	-	-	SSL38		SSL12			SSL58			SSL34	

For SI: 1 inch = 25.4 mm, 1 ft-lbf = 1.356 N-m.

¹For through bolt applications the actual hole depth is given by the minimum hole depth plus the maximum thickness of fixture less the thickness of the actual part(s) being fastened to the base material ($h_{o,act} = h_o + t - t_p$). See Figure 3.

²For through bolt applications the minimum diameter of hole clearance in fixture is 1/16-inch larger than the nominal outside anchor diameter.

³The notation in brackets is for the 2006 IBC.

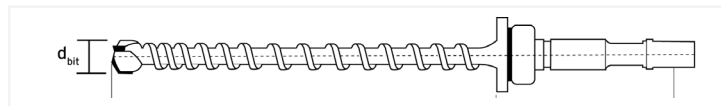

Stop Drill Bit

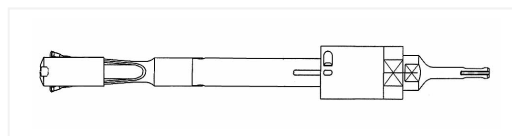

Undercut Drill Bit

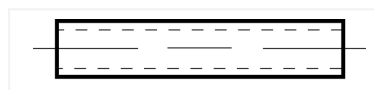

Setting Sleeve

FIGURE 4—STOP DRILL BIT, UNDERCUT DRILL BIT AND SETTING SLEEVE

TABLE 4—DUC UNDERCUT ANCHOR DESIGN INFORMATION
(For use with load combinations taken from ACI 318-14 Section 5.3 or ACI 318-11 Section 9.2)¹

Anchor Property / Setting Information	Notation	Units	Nominal Anchor Size / Rod Diameter (inch)									
			³ / ₈		¹ / ₂		⁵ / ₈		³ / ₄			
Anchor category	1, 2, or 3	-	1		1		1		1			
Outside diameter of anchor	d_a [d _o] ⁸	in. (mm)	0.625 (15.9)		0.750 (19.1)		1.000 (25.4)		1.125 (28.6)			
Effective embedment depth	h_{ef}	in. (mm)	² / ₃ (70)	4 (102)	4 (102)	5 (127)	⁶ / ₄ (171)	⁴ / ₂ (114)	⁷ / ₂ (190)	9 (229)	5 (127)	10 (254)
Minimum concrete member thickness	h_{min}	in. (mm)	⁵ / ₂ (140)	8 (203)	8 (203)	10 (254)	¹³ / ₂ (343)	9 (229)	15 (381)	18 (457)	10 (254)	20 (508)
		for $c_{ac} \geq$	in. (mm)	⁴ / ₈ (105)	6 (152)	6 (152)	⁷ / ₂ (190)	¹⁰ / ₈ (257)	⁶ / ₄ (171)	¹¹ / ₄ (286)	¹³ / ₂ (343)	⁷ / ₂ (190)
	h_{min}	in. (mm)	⁴ / ₈ (105)	6 (152)	6 (152)	⁷ / ₂ (190)	¹⁰ / ₈ (257)	⁶ / ₄ (171)	¹¹ / ₄ (286)	¹³ / ₂ (343)	⁷ / ₂ (190)	15 (381)
		for $c_{ac} \geq$	in. (mm)	⁵ / ₂ (140)	¹⁰ / ₄ (260)	⁹ / ₄ (235)	13 (330)	²⁰ / ₄ (514)	⁹ / ₂ (241)	21 (533)	27 (686)	¹⁰ / ₂ (267)
Minimum edge distance	c_{min}	in. (mm)	² / ₄ (57)	³ / ₄ (82)	³ / ₄ (82)	4 (102)	⁵ / ₈ (137)	³ / ₈ (92)	6 (152)	⁷ / ₄ (184)	4 (102)	8 (203)
Minimum spacing distance	s_{min}	in. (mm)	² / ₄ (70)	4 (102)	4 (102)	5 (127)	⁶ / ₄ (171)	⁴ / ₂ (114)	⁷ / ₂ (190)	9 (229)	5 (127)	10 (254)
STEEL STRENGTH IN TENSION AND SHEAR³												
Minimum specified yield strength of anchor rod	f_y	ksi (N/mm ²)	36 (248)	105 (723)	36 (248)	105 (723)	105 (723)	36 (248)	105 (723)	105 (723)	36 (248)	105 (723)
Minimum specified ultimate tensile strength of anchor rod	f_{uta}	ksi (N/mm ²)	58 (400)	125 (860)	58 (400)	125 (860)	125 (860)	58 (400)	125 (860)	125 (860)	58 (400)	125 (860)
Tensile stress area of anchor rod steel	$A_{se,N}$ [A_{se}] ⁸	in. ² (mm ²)	0.0775 (50)		0.1419 (91)		0.2260 (146)		0.3345 (245)			
Steel strength in tension, static	N_{sa}	lb. (kN)	4,495 (20.1)	9,685 (43.2)	8,230 (36.7)	17,735 (79.1)	17,735 (79.1)	13,100 (58.5)	28,250 (126.1)	28,250 (126.1)	19,400 (86.3)	41,810 (186.0)
Steel strength in shear, static ⁹	V_{sa}	lb. (kN)	2,245 (10.0)	4,855 (21.7)	4,110 (18.4)	8,855 (39.5)	8,855 (39.5)	6,560 (29.3)	14,110 (63.0)	14,110 (63.0)	9,685 (43.2)	20,875 (93.2)
Steel strength in shear, seismic ⁹	$V_{sa,eq}$	lb. (kN)	2,245 (10)	4,855 (21.7)	4,110 (18.4)	8,855 (39.5)	8,855 (39.5)	6,560 (29.3)	14,110 (63)	14,110 (63)	9,685 (43.2)	20,875 (93.1)
Reduction factor for steel strength in tension ²	ϕ	-	0.75									
Reduction factor for steel strength in shear ²	ϕ	-	0.65									
CONCRETE BREAKOUT STRENGTH IN TENSION⁷												
Effectiveness factor uncracked concrete	k_{uncr}	-	30		30		30		30		30	
Effectiveness factor cracked concrete	k_{cr}	-	24		24		24		24		24	
Modification factor for cracked and uncracked concrete ⁴	$\psi_{c,N}$	-	1.0 (see note 4)		1.0 (see note 4)		1.0 (see note 4)		1.0 (see note 4)		1.0 (see note 4)	
Reduction factor for concrete breakout strength in tension ²	ϕ	-	0.65 (Condition B)									
Reduction factor for concrete breakout strength in shear ²	ϕ	-	0.70 (Condition B)									
PULLOUT STRENGTH IN TENSION⁷												
Characteristic pullout strength, uncracked concrete (2,500 psi)	$N_{p,uncr}$	lb. (kN)	See note 6		See note 6		See note 6		See note 6		See note 6	
Characteristic pullout strength, cracked concrete (2,500 psi) ⁵	$N_{p,cr}$	lb. (kN)	See note 6	9,000 (40.2)	See note 6	11,500 (51.3)	See note 6	15,000 (67.0)	See note 6	22,000 (98.2)	See note 6	22,000 (98.2)
Characteristic pullout strength, seismic (2,500 psi) ⁵	$N_{p,eq}$	lb. (kN)	See note 6	9,000 (40.2)	See note 6	11,500 (51.3)	See note 6	15,000 (67.0)	See note 6	22,000 (98.2)	See note 6	22,000 (98.2)
Reduction factor for pullout strength in tension ²	ϕ	-	0.65 (Condition B)									
PRYOUT STRENGTH IN SHEAR⁷												
Coefficient for prout strength	k_{cp}	-	2.0		2.0		2.0		2.0		2.0	
Reduction factor for prout strength in shear ²	ϕ	-	0.70 (Condition B)									

For **SI**: 1 inch = 25.4 mm, 1 ksi = 6.895 MPa (N/mm²), 1 lbf = 0.0044 kN, 1 in² = 645 mm².

¹The data in this table is intended to be used with the design provisions of ACI 318-14 Chapter 17 or ACI 318-11 Appendix D, as applicable; for anchors resisting seismic load combinations the additional requirements of ACI 318-14 17.2.3 or ACI 318-11 D.3.3, as applicable, shall apply.

²All values of ϕ were determined from the load combinations of IBC Section 1605.2, ACI 318-14 Section 5.3 or ACI 318-11 Section 9.2, as applicable. If the load combinations of ACI 318-11 Appendix C are used, then the appropriate value of ϕ must be determined in accordance with ACI 318-11 D.4.4.

For reinforcement that meets ACI 318-14 Chapter 17 or ACI 318-11 Appendix D requirements for Condition A, see ACI 318-14 17.3.3(c) or ACI 318-11 D.4.3(c), as applicable, for the appropriate ϕ factor when the load combinations of IBC Section 1605.2, ACI 318-14 Section 5.3 or ACI 318-11 Section 9.2 are used, as applicable.

³Anchors are considered a ductile steel element as defined by ACI 318-14 2.3 or ACI 318-11 D.1, as applicable.

⁴For all design cases $\psi_{c,N}=1.0$. The appropriate effectiveness factor for cracked concrete (k_{cr}) or uncracked concrete (k_{uncr}) must be used.

⁵For all design cases $\psi_{c,P}=1.0$. For the calculation of N_{pn} , see Section 4.1.4 of this report.

⁶Pullout strength does not control design of indicated anchors. Do not calculate pullout strength for indicated anchor size and embedment.

⁷Anchors are permitted to be used in lightweight concrete in accordance with Section 4.1.12 of this report.

⁸The notation in brackets is for the 2006 IBC.

⁹Shear strength values are based on standard (pre-set) installation, and must be used for both standard (pre-set) and through-bolt installations.

TABLE 5—EXAMPLE ALLOWABLE STRESS DESIGN VALUES FOR ILLUSTRATIVE PURPOSES^{1,2,3,4,5,6,7,8,9}

Nominal Anchor Size (inch)	Nominal Embedment Depth (inches)	Effective Embedment (inches)	Anchor Rod Designation (ASTM)	Allowable Tension Load (pounds)
3/8	3 1/8	2 3/4	A36	2,280
	4 3/8	4	A193, Grade B7	4,910
1/2	4 1/4	4	A36	4,170
	5 1/4	5	A193, Grade B7	7,365
	7	6 3/4	A193, Grade B7	8,990
5/8	5	4 1/2	A36	6,290
	8	7 1/2	A193, Grade B7	13,530
	9 1/2	9	A193, Grade B7	14,315
3/4	5 7/8	5	A36	7,365
	10 7/8	10	A193, Grade B7	20,830

For SI: 1 inch = 25.4 mm, 1 lbf = 0.0044 kN.

¹ Single anchor with static tension load only.

² Concrete determined to remain uncracked for the life of the anchorage.

³ Load combinations from ACI 318-14 Section 5.3 or ACI 318-11 Section 9.2, as applicable (no seismic loading considered).

⁴ 30% dead load and 70% live load, controlling load combination 1.2D + 1.6L.

⁵ Calculation of weighted average for $\alpha = 1.2(0.3) + 1.6(0.7) = 1.48$.

⁶ $f'_c = 2,500$ psi (normal weight concrete).

⁷ $C_{a1} = C_{a2} \geq C_{ac}$.

⁸ $h \geq h_{min}$.

⁹ Values are for Condition B where supplementary reinforcement in accordance with ACI 318-14 17.3.3(c) or ACI 318-11 D.4.3(c), as applicable, is not provided.

Given: Calculate the factored resistance strength, ϕN_n , and the allowable stress design value, $T_{allowable,ASD}$, for a 3/8-inch undercut anchor with ASTM A193, Grade B7 anchor rod designation assuming the given conditions in Table 5.

Calculation in accordance with ACI 318-14 Chapter 17, ACI 318-11 Appendix D and this report:	ACI 318-14 Ref.	ACI 318-11 Ref.	Report Ref.
<p>Step 1. Calculate steel strength of a single anchor in tension:</p> $\phi N_{sa} = (0.75)(9,685) = 7,264 \text{ lbs.}$	17.4.1.2	D.5.1.2	Table 4
<p>Step 2. Calculate concrete breakout strength of a single anchor in tension:</p> $\phi N_{cb} = \phi \frac{A_{Nc}}{A_{Nc0}} \psi_{ed,N} \psi_{c,N} \psi_{cp,N} N_b$ $N_b = k_c \lambda_\alpha \sqrt{f'_c} (h_{ef})^{1.5}$ $N_b = (30)(1.0) \sqrt{2,500} (4.0)^{1.5} = 12,000 \text{ lbs.}$ $\phi N_{cb} = (0.65) \frac{(144.0)}{(144.0)} (1.0)(1.0)(1.0)(12,000) = 7,800 \text{ lbs.}$	17.4.2.1	D.5.2.1	Table 4
<p>Step 3. Calculate pullout strength of a single anchor:</p> $\phi N_{pn} = \phi N_{p,uncr} \psi_{c,P} \left(\frac{f'_{c,act}}{2,500} \right)^{0.5}$ <p>$\phi N_{pn} = \text{N/A}$, pullout strength does not control</p>	17.4.2.2	D.5.2.2	Table 4
<p>Step 4. Determine controlling factored resistance strength in tension:</p> $\phi N_n = \min[\phi N_{sa}, \phi N_{cb}, \phi N_{pn}] = \phi N_{sa} = 7,264 \text{ lbs.}$	17.3.1.1	D.4.1.1	-
<p>Step 5. Calculate allowable stress design conversion factor for loading condition: Controlling load combination: 1.2D + 1.6L $\alpha = 1.2(30\%) + 1.6(70\%) = 1.48$</p>	5.3	9.2	-
<p>Step 6. Calculate the converted allowable stress design value:</p> $T_{allowable,ASD} = \frac{\phi N_n}{\alpha} = \frac{7,264}{1.48} = 4,908 \text{ lbs.}$	-	-	Section 4.2

FIGURE 5—DUC UNDERCUT ANCHOR EXAMPLE STRENGTH DESIGN CALCULATION INCLUDING ASD CONVERSION FOR ILLUSTRATIVE PURPOSES

Given:

Two 3/8" undercut anchors
 A 193, Grade B7 designation
 Concrete compressive strength:
 $(f'_c) = 4,000$ psi
 No supplemental reinforcement:
 (Condition B per ACI 318-14
 17.3.3(c) or ACI 318-11 D.4.3(c))
 Assume uncracked concrete, no
 seismic, no loading eccentricity and a
 rigid plate

$h_a = 8.0$ in.
 $h_{ef} = 4.0$ in.
 $s_a = 5.0$ in.
 $c_{a1} = c_{a,min} = 4.0$ in.
 $c_{a2} \geq 1.5c_{a1}$

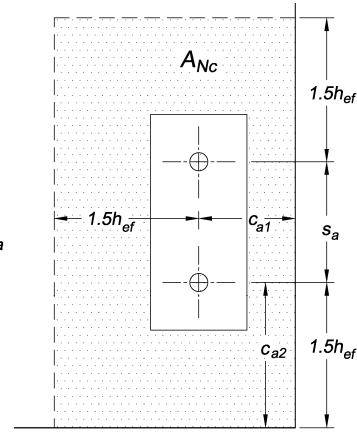
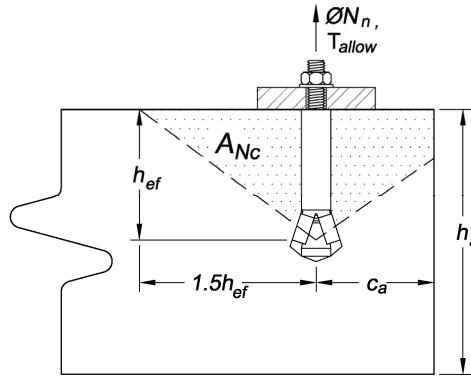

Calculate the factored resistance design strength in tension and equivalent allowable stress design load for the configuration.

Calculation in accordance with ACI 318-14, ACI 318-11 and this report:	ACI 318-14 Ref.	ACI 318-11 Ref.	Report Ref.
Step 1. Verify minimum member thickness, spacing and edge distance: $h_a = 8.0$ in. $\geq h_{min} = 8.0$ in. \therefore OK $s_a = 5.0$ in. $\geq s_{min} = 4.0$ in. \therefore OK $c_{a,min} = 4.0$ in. $\geq c_{min} = 3.25$ in. \therefore OK	17.7	D.8	Table 4
Step 2. Calculate steel strength of anchor group in tension: $N_{sag} = nN_{sa} = (2)(9,685) = 19,370$ lbs. Calculate steel capacity: $\phi N_{sag} = 0.75 \cdot 19,370$ lbs. = 14,525 lbs.	17.4.1.2	D.5.1.2	Table 4
Step 3. Calculate concrete breakout strength of anchor group in tension: $N_{cbg} = \frac{A_{Nc}}{A_{Nc0}} \psi_{ec,N} \psi_{ed,N} \psi_{c,N} \psi_{cp,N} N_b$	17.4.2.1(b)	D.5.2.1(b)	-
Step 3a. Calculate A_{Nc0} and A_{Nc} $A_{Nc0} = 9h_{ef}^2 = 9 \cdot (4.0)^2 = 144$ in. ² $A_{Nc} = (c_{a1} + 1.5h_{ef}) \cdot (3.0 h_{ef} + s_a) = (4.0 + 6.0) \cdot (3.0 \cdot 4.0 + 5.0) = 170$ in. ²	17.4.2.1(b)	D.5.2.1(b)	Table 4
Step 3b. Calculate $\psi_{ec,N} = \frac{1}{(1 + \frac{2e'_N}{3h_{ef}})} \leq 1.0$; $e'_N = 0 \therefore \psi_{ec,N} = 1.0$	17.4.2.4	D.5.2.4	-
Step 3c. Calculate $\psi_{ed,N} = 1.0$ if $c_{a,min} \geq 1.5h_{ef}$; $\psi_{ed,N} = 0.7 + 0.3 \frac{c_{a,min}}{1.5h_{ef}}$ if $c_{a,min} < 1.5h_{ef}$ $c_{a,min} = 4.0$ in. $\geq 1.5h_{ef} = 6.0$ in. $\therefore \psi_{ed,N} = 0.7 + 0.3 \frac{4.0}{6.0} = 0.90$	17.4.2.5	D.5.2.5	Table 4
Step 3d. Calculate $\psi_{c,N} = 1.0$ (uncracked concrete)	17.4.2.6	D.5.2.6	Table 4
Step 3e. Calculate $\psi_{cp,N} = 1.0$ if $c_{a,min} \geq c_{ac}$; $\psi_{cp,N} = \frac{c_{a,min}}{c_{ac}} \geq \frac{1.5h_{ef}}{c_{ac}}$ if $c_{a,min} < c_{ac}$ $c_{a,min} = 4.0$ in. $< c_{ac} = 6.0$ in. $\therefore \psi_{cp,N} = \frac{c_{a,min}}{c_{ac}} \geq \frac{1.5h_{ef}}{c_{ac}} = \frac{4.0}{6.0} \geq \frac{6.0}{6.0} = 1.0$	17.4.2.7	D.5.2.7	Table 4
Step 3f. Calculate $N_b = k_{cr} \lambda \alpha \sqrt{f'_c} h_{ef}^{1.5} = 30(1.0) \sqrt{4,000} \cdot 4.0^{1.5} = 15,180$ lbs.	17.4.2.2	D.5.2.2	Table 4
Step 3g. Calculate concrete breakout strength of anchor group in tension: $N_{cbg} = (170/144) \cdot 1.0 \cdot 0.90 \cdot 1.0 \cdot 1.0 \cdot 15,180 = 16,125$ lbs. Calculate concrete breakout capacity = $\phi N_{cbg} = 0.65 \cdot 16,125 = 10,480$ lbs.	17.4.2.1(b)	D.5.2.1(b)	-
Step 4. Calculate nominal pullout strength of a single anchor in tension: $N_{pn} = \psi_{c,p} \cdot N_{pn,f_c}$ – Pullout does not control; therefore it needs not be considered.	17.4.3.1	D.5.3.1	-
Step 5. Determine controlling resistance strength of the anchor group in tension: $\phi N_n = \min \{ \phi N_{sag}, \phi N_{cbg}, n \phi N_{pn} \} = \phi N_{cbg} = 10,480$ lbs.	17.3.1.1	D.4.1.1	-
Step 6. Calculate allowable stress design conversion factor for loading condition: Assume controlling load combination: 1.2D + 1.6L ; 50% Dead Load, 50% Live Load $\alpha = 1.2(50\%) + 1.6(50\%) = 1.40$	5.3	9.2	-
Step 7. Calculate allowable stress design value: $T_{allowable,ASD} = \frac{\phi N_n}{\alpha} = \frac{10,480}{1.40} = 7,485$ lbs.	5.3	9.2	-

FIGURE 6—EXAMPLE CALCULATION FOR DUC UNDERCUT ANCHORS

Given:

Two 3/8" undercut anchors
 A 193, Grade B7 designation
 Concrete compressive strength:
 $(f'_c) = 3,000$ psi
 No supplemental reinforcement:
 (Condition B per ACI 318-14
 17.3.3(c) or ACI 318-11 D.4.3(c))
 Assume uncracked concrete, no
 seismic, no loading eccentricity and a
 rigid plate
 $h_a = 8.0$ in.
 $h_{ef} = 4.0$ in.
 $s_a = 5.0$ in.
 $c_{a1} = c_{a,min} = 4.0$ in.
 $c_{a2} \geq 1.5c_{a1}$

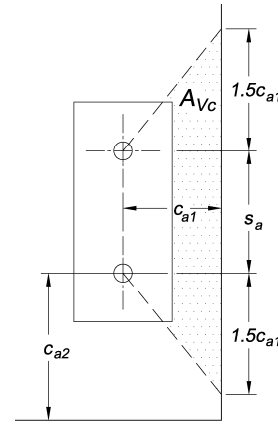
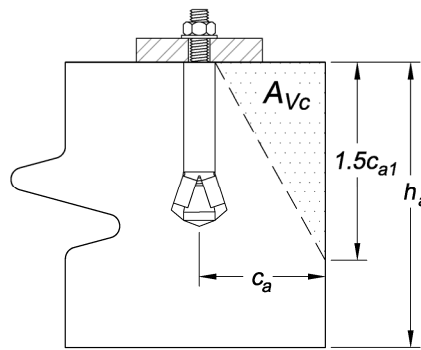

Calculate the factored resistance design strength in shear and equivalent allowable stress design load for the configuration.

Calculation in accordance with ACI 318-14, ACI 318-11 and this report:	ACI 318-14 Ref.	ACI 318-11 Ref.	Report Ref.
Step 1. Verify minimum member thickness, spacing and edge distance: $h_a = 8.0$ in. $\geq h_{min} = 8.0$ in. \therefore OK $s_a = 5.0$ in. $\geq s_{min} = 4.0$ in. \therefore OK $c_{a,min} = 4.0$ in. $\geq c_{min} = 3.25$ in. \therefore OK	17.7	D.8	Table 4
Step 2. Calculate steel strength of anchor group in shear: $V_{sag} = n \cdot V_{sa} = 2 \cdot 4,855$ lbs. = 9,710 lbs. Calculate steel capacity: $\phi V_{sag} = 0.65 \cdot 9,710$ lbs. = 6,310 lbs.	17.5.1.2	D.6.1.2	Table 4
Step 3. Calculate concrete breakout strength of anchor group in shear: $V_{cbg} = \frac{A_{Vc}}{A_{Vc0}} \psi_{ec,v} \psi_{ed,v} \psi_{c,v} \psi_{h,v} V_b$	17.5.2.1(b)	D.6.2.1(b)	-
Step 3a. Calculate A_{Vc0} and A_{Vc} $A_{Vc0} = 4.5 (c_{a1})^2 = 4.5 \cdot (4.0)^2 = 72$ in. ² $A_{Vc} = (1.5 c_{a1}) \cdot (1.5 c_{a1} + s_a + 1.5 c_{a1}) = (6.0)(6.0 + 6.0 + 6.0) = 108$ in. ²	17.5.2.1	D.6.2.1	Table 4
Step 3b. Calculate $\psi_{ec,v} = \frac{1}{(1 + \frac{2e'}{3c_{a1}})} \leq 1.0$; $e'_v = 0 \therefore \psi_{ec,v} = 1.0$	17.5.2.5	D.6.2.5	-
Step 3c. Calculate $\psi_{ed,v} = 1.0$ if $c_{a2} \geq 1.5c_{a1}$; $\psi_{ed,v} = 0.7 + 0.3 \frac{c_{a2}}{1.5c_{a1}}$ if $c_{a2} < 1.5c_{a1}$ $c_{a2} \geq 1.5 c_{a1} \therefore \psi_{ed,v} = 1.0$	17.5.2.6	D.6.2.6	-
Step 3d. Calculate $\psi_{c,v} = 1.4$ (uncracked concrete)	17.5.2.7	D.6.2.7	-
Step 3e. Calculate $\psi_{h,v} = \sqrt{\frac{1.5c_{a1}}{h_a}}$; for members where $h_a < 1.5c_{a1}$ $h_a = 8.0 \geq 1.5c_{a1} = 6.0 \therefore \psi_{h,v} = 1.0$	17.5.2.8	D.6.2.8	-
Step 3f. Calculate $V_b = 7 \left(\frac{l_e}{d_a}\right)^{0.2} \lambda \alpha \sqrt{d_a} \sqrt{f'_c} (c_{a1})^{1.5}$ $7 \left(\frac{3.0}{0.625}\right)^{0.2} (1.0) \sqrt{0.625} \sqrt{4000} (4.0)^{1.5} = 3,830$ lbs.	17.5.2.2	D.6.2.2	Table 4
Step 3g. Calculate concrete breakout strength of anchor group in shear: $V_{cbg} = (108/72) \cdot 1.0 \cdot 1.0 \cdot 1.4 \cdot 1.0 \cdot 3,830 = 8,045$ lbs. Calculate concrete breakout capacity: $\phi V_{cbg} = 0.70 \cdot 8,045 = 5,630$ lbs.	17.5.2.1(b)	D.6.2.1(b)	-
Step 4. Calculate nominal pryout strength of an anchor group in shear: $V_{cpg} = k_{cp} N_{cbg} = 2.0 \cdot 17,455$ lbs = 34,915 lbs. Calculate pryout capacity: $\phi V_{cpg} = 0.70 \cdot 34,915$ lbs. = 24,440 lbs.	17.5.3.1(b)	D.6.3.1(b)	Table 4
Step 5. Determine controlling resistance strength in shear: $\phi V_n = \min \{ \phi V_{sag}, \phi V_{cbg}, \phi V_{cpg} \} = \phi V_{cbg} = 5,630$ lbs.	17.3.1.1	D.4.1.1	-
Step 6. Calculate allowable stress design conversion factor for loading condition: Controlling load combination: 1.2D + 1.6L; 50% Dead Load, 50% Live Load $\alpha = 1.2(30\%) + 1.6(70\%) = 1.40$	5.3	9.2	-
Step 7. Calculate allowable stress design value: $V_{allowable,ASD} = \frac{\phi V_n}{\alpha} = \frac{5,630}{1.40} = 4,020$ lbs.	5.3	9.2	-

FIGURE 7—EXAMPLE CALCULATION FOR DUC UNDERCUT ANCHORS

DIVISION: 03 00 00—CONCRETE
Section: 03 16 00—Concrete Anchors

DIVISION: 05 00 00—METALS
Section: 05 05 19—Post-Installed Concrete Anchors

REPORT HOLDER:

MITEK® INC.

EVALUATION SUBJECT:

DUC UNDERCUT ANCHORS

1.0 REPORT PURPOSE AND SCOPE

Purpose:

The purpose of this evaluation report supplement is to indicate that the DUC Undercut Anchors, described in ICC-ES evaluation report [ESR-1970](#), have also been evaluated for compliance with the codes noted below as adopted by Los Angeles Department of Building and Safety (LADBS).

Applicable code editions:

- 2020 *City of Los Angeles Building Code* (LABC)
- 2020 *City of Los Angeles Residential Code* (LARC)

2.0 CONCLUSIONS

The DUC Undercut Anchors, described in Sections 2.0 through 7.0 of the evaluation report [ESR-1970](#), comply with LABC Chapter 19, and LARC, and are subject to the conditions of use described in this report.

3.0 CONDITIONS OF USE

The DUC Undercut Anchors described in this evaluation report supplement must comply with all of the following conditions:

- All applicable sections in the evaluation report [ESR-1970](#).
- The design, installation, conditions of use and labeling of the anchors are in accordance with the 2018 *International Building Code*® (IBC) provisions noted in the evaluation report [ESR-1970](#).
- The design, installation and inspection are in accordance with additional requirements of LABC Chapters 16 and 17, as applicable.
- Under the LARC, an engineered design in accordance with LARC Section R301.1.3 must be submitted.
- The allowable and strength design values listed in the evaluation report and tables are for the connection of the anchors to the concrete. The connection between the anchors and the connected members shall be checked for capacity (which may govern).
- For the design of wall anchorage assemblies to flexible diaphragms, the anchor shall be designed per the requirements of City of Los Angeles Information Bulletin P/BC 2020-071.

This supplement expires concurrently with the evaluation report, reissued June 2020 and revised July 2020.

DIVISION: 03 00 00—CONCRETE**Section: 03 16 00—Concrete Anchors****DIVISION: 05 00 00—METALS****Section: 05 05 19—Post-Installed Concrete Anchors****REPORT HOLDER:****MITEK® INC.****EVALUATION SUBJECT:****DUC UNDERCUT ANCHORS****1.0 REPORT PURPOSE AND SCOPE****Purpose:**

The purpose of this evaluation report supplement is to indicate that the DUC Undercut Anchors, described in ICC-ES evaluation report ESR-1970, have also been evaluated for compliance with the codes noted below.

Applicable code editions:

- 2020 and 2017 *Florida Building Code—Building*
- 2020 and 2017 *Florida Building Code—Residential*

2.0 CONCLUSIONS

The DUC Undercut Anchors, described in Sections 2.0 through 7.0 of ICC-ES evaluation report ESR-1970, comply with the *Florida Building Code-Building* and the *Florida Building Code-Residential* provided the design requirements are determined in accordance with the *Florida Building Code-Building* or the *Florida Building Code-Residential*, as applicable. The installation requirements noted in the ICC-ES evaluation report ESR-1970 for the 2018 and 2015 *International Building Code*® meet the requirements of the *Florida Building Code-Building* or the *Florida Building Code-Residential*, as applicable, with the following conditions:

Use of the DUC Undercut Anchors has also been found to be in compliance with the High-Velocity Hurricane Zone provisions of the *Florida Building Code-Building* or the *Florida Building Code-Residential* with the following condition.

- a) For connections subject to uplift, the connection must be designed for no less than 700 pounds (3114 N).

For products falling under Florida Rule 61G20-3, verification that the report holder's quality assurance program is audited by a quality assurance entity approved by the Florida Building Commission for the type of inspections being conducted is the responsibility of an approved validation entity (or the code official when the report holder does not possess an approval by the Commission).

This supplement expires concurrently with the evaluation report, reissued June 2020 and revised July 2020.